

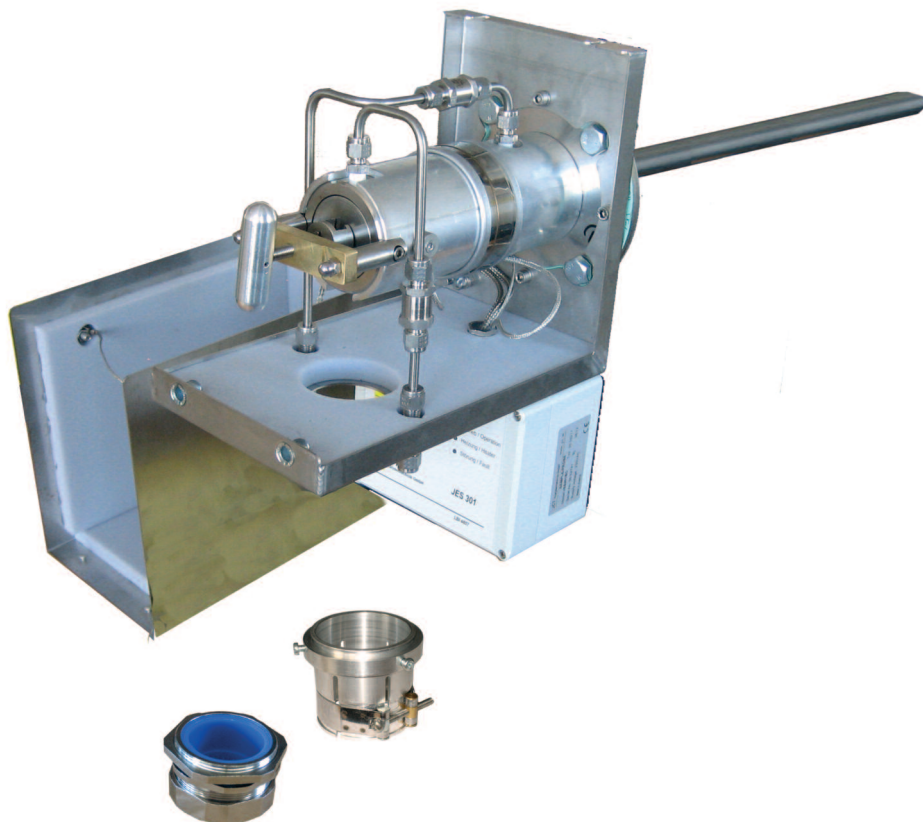

JES-301 Heated Gas Sampling Probe



JCT
Analysentechnik

Gas Sampling Probes

Heated Sample Lines

Sample Gas Coolers

Condensate Treatment

Accessories

Gas Conditioning Systems

Sample Gas Converters

images are representative

APPLICATION

- Representative continuous gas sampling in processes containing dust and humidity
- Extractive gas analysis
- Emission (CEMS) and process monitoring
- Removal of dust from the sample gas

BENEFITS

- No condensation or chemical reactions of sample gas
- Convenient filter replacement
- Low maintenance
- Safe unattended operation
- Easy start-up
- Even for high dust concentrations
- Reliable protection of the analyzer system

FEATURES

- Homogeneous heating without cold spots
- Large active filter surface
- Filtration from outside to inside
- Filter element change without tools
- Different material of filter elements
- Electronic temperature controller including over temperature protection
- Temperature status contact
- Weather protection housing
- Various options and upgrades
- Wide range of accessories

DIMENSIONS

Dimensions in mm

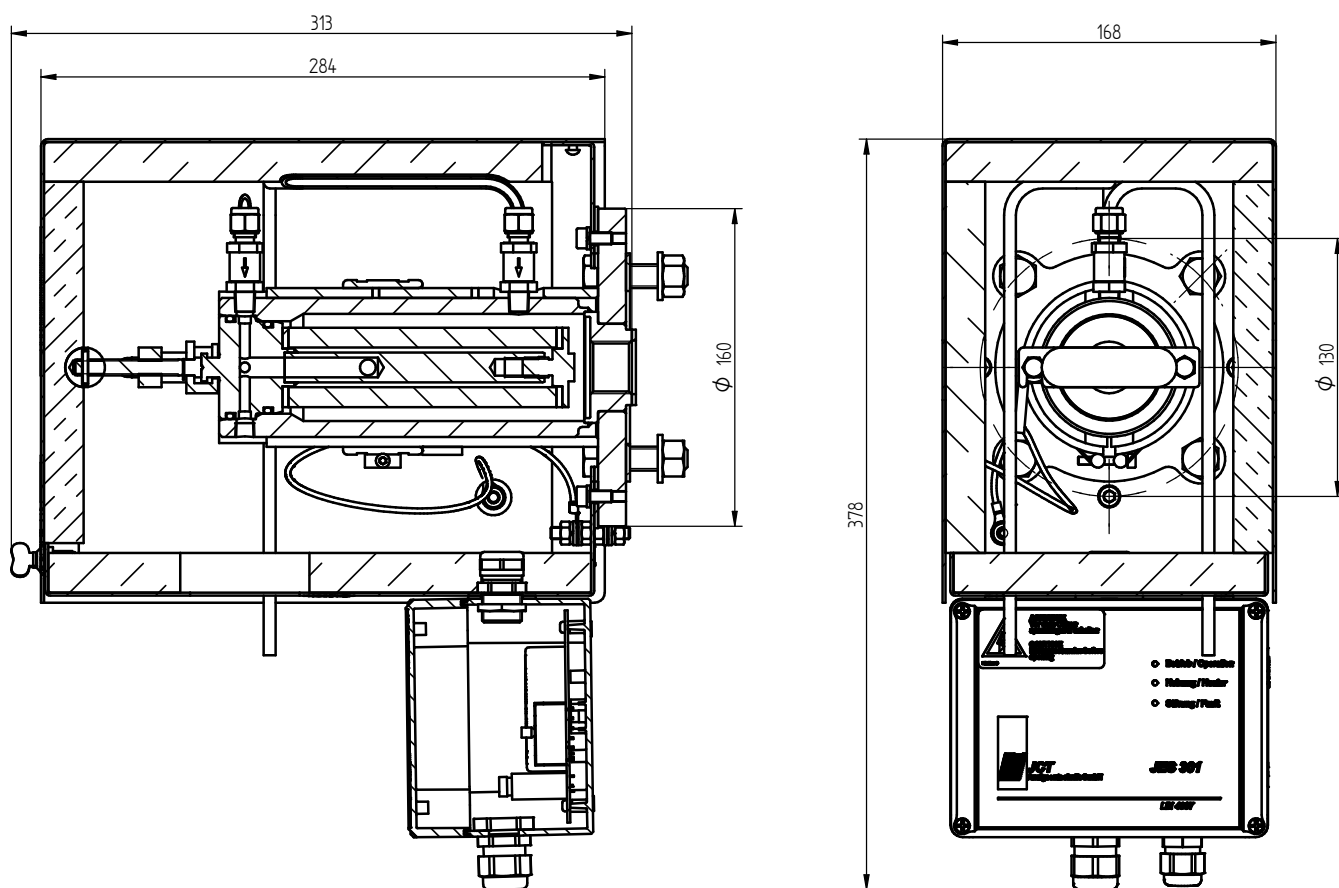

ORDER CODE

Model	Filter		Options			Power Supply and Flange			
	2 μ m ceramic	0,2 μ m ceramic coated	Back purge port *1	Calibration port *1	Temperature controller	Power supply 230 VAC Flange DN65/PN6	Power supply 230 VAC Flange 2" ANSI (Z)	Power supply 115 VAC (X) Flange DN65/PN6	Power supply 115 VAC (X) Flange 2" ANSI (Z)
JES-301	X				X	35.00210	35.00221	35.00310	35.00321
JES-301B		X	X		X	35.00212	35.00213	35.00312	35.00313
JES-301C	X			X	X	35.00214	35.00239	35.00314	35.00316
JES-301BC		X	X	X	X	35.00217	35.00231	35.00317	35.00318
JES-301H	X					35.00208	35.00332	35.00308	35.00309
JES-301BH		X	X			35.00220	35.00235	35.00328	35.00329
JES-301CH	X			X		35.00226	35.00236	35.00326	35.00327
JES-301BCH		X	X	X		35.00238	35.00237	35.00330	35.00331

Scope of delivery: sampling probe, mounting material, flange gasket, gasket for sampling pipe, operating manual
 *1...with non-return valve

TECHNICAL DATA

Model

JES-301

Description	stationary gas sampling probe
-------------	-------------------------------

Operation

Temperature	180 °C (ex works), adjustable 5° C to 200 °C
Low temperature alarm / excess temperature limit	-30 K /+20 K fix to set point
Operating pressure	max. 2 bara (max. 7 bara optional)
Mounting position	5° to 15° incline (recommended), torsion angle max. 45°
Heating-up time	40 min
Ambient temperature	for start-up -20 °C to 60 °C for continuous operation -30 °C to 60 °C

Construction

Dimensions over all (W x H x D)	168 x 378 x 313 mm
Dimensions connection box (W x H x D)	120 x 160 x 90 mm
Filter element	2 µm ceramic or 0,2 µm ceramic coated
Active filter surface	170 cm ²
Mounting flange	DN 65, PN6; form A according to EN 1092-1; SS316L or 2" ANSI 150 lbs; according to ASME B16.5
Sample gas inlet	G 3/4" female thread
Sample gas outlet	1/8" NPT female thread
Calibration gas connection (option)	pipe 6 mm, SS316
Back purge connection (option)	pipe 6 mm, SS316
Gas wetted materials	SS316L, ceramic, Viton®
Protection class	connection box IP65, probe IP43
Weight	12,5 kg
Weather protection housing	SS304, thermal insulated, colour stainless steel natural
Approvals / signs	CE

Electrics

Power supply	230 VAC 50 Hz or 115 VAC 60 Hz
Power consumption	approx. 505 VA
Temperature controller / sensor	electronic / PT100
Electrical connection	spring type terminals, clamping range 0,08 to 2,5 mm ²
Switching capacity status contact (volt free)	230 VAC / 2 A, min. 5 VDC / 5 mA

GAS FLOW DIAGRAM

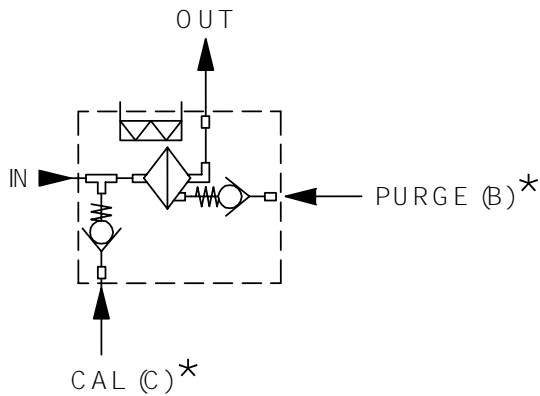

*... not included in all models

**Pressure characteristics in dependence of the gas flow
(for new filter element and 20 °C)**

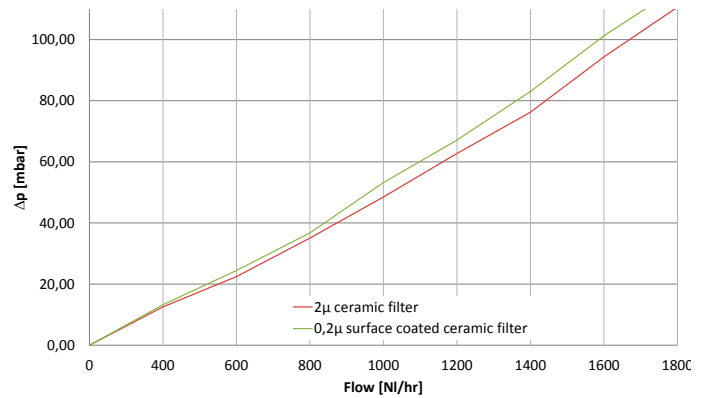

UPGRADE OPTIONS AND ACCESSORIES

Put together a sampling probe exactly according to your requirements by choosing additional modules, e.g. solenoid valves, controllers and air accumulators. Please refer to this separate product data sheet for further information:

- Upgrade Options for JES-301 Gas Sampling Probes**

Filter elements in various materials

Dilution units

Back purge control valves

Ball valves for sample gas inlets and outlets

Air accumulators

High temperature versions

Temperature display for temperature controller

JCT Analysentechnik GmbH offers a wide range of accessories. Please refer to separate data sheets for further information:

- JER Sampling Pipes and JHD Pre-Filters**

Sampling pipes in various materials and lengths

In-Situ pre-filter in various materials

Extension pipes in various materials

- JES-301K Back Purge Control Unit**

- JES-301 Accessories**

Flange adapters

Accessories for gas connections

Accessories for heated sample pipes

Gas Sampling **Probes**

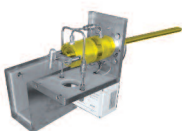

Heated Sample **Lines**



Sample Gas **Coolers**



Gas Conditioning **Systems**



NOx **Converter**



and solutions for

