



**JCT**  
Analysentechnik

# JES-360 Gas Sampling Probe for Pre-Filter Back Flush



## Gas Sampling Probes

Heated Sample Lines

Sample Gas Coolers

Condensate Treatment

Accessories

Gas Conditioning Systems

Sample Gas Converters

### APPLICATION

- Representative continuous gas sampling in processes containing high dust and humidity
- Extractive gas analysis
- Emission (CEMS) and process monitoring
- Removal of dust from the sample gas

### BENEFITS

- Cost-optimized solutions
- No condensation or chemical reactions of sample gas
- Convenient filter replacement
- Low maintenance
- Safe unattended operation
- Easy start-up
- Even for high dust concentrations
- Reliable protection of the analyzer system
- Long filter lifetime

### FEATURES

- Modular design for custom-tailored applications
- Highly efficient filter cleaning
- Homogeneous heating without cold spots
- Large active filter surface
- Filtration from outside to inside
- Filter element change without tools
- Different material of filter elements
- Electronic temperature controller including over temperature protection
- Temperature status contact
- Weather protection housing
- Various options and upgrades
- Wide range of accessories
- Integrated back flush / back purge controller (option)

## TECHNICAL DATA

### Model

**JES-360**

Description	stationary gas sampling probe for pre-filter back flush
-------------	---

### Operation

Temperature	180 °C (ex works), adjustable 5 °C to 200 °C
Status limiter set values	-30 K /+20 K fixed to set point
Operating pressure	max. 2 bara (max. 7 bara optional)
Mounting position	5° to 15° incline (recommended), torsion angle max. 45°
Heating-up time	< 1 h
Ambient temperature	for start-up -20 °C to 60 °C for continuous operation -30 °C to 60 °C

### Construction

Dimensions over all (W x H x D)	375 x 418 x 449 mm
Dimensions connection box (W x H x D)	120 x 160 x 90 mm
Filter element	2 µm ceramic or 0,2 µm ceramic surface coated
Active filter surface	170 cm <sup>2</sup>
Mounting flange	DN 65, PN6; form A according to EN 1092-1; SS316L or 2" ANSI 150 lbs; according to ASME B16.5
Sample gas inlet	G 3/4" female thread
Sample gas outlet	1/8" NPT female thread
Calibration gas connection (feature C)	pipe 6 mm, SS316
Back purge connection (feature K)	pipe 6 mm, SS316
Connection pre-filter back flush (feature J)	NPT 3/8" female thread
Gas wetted materials	SS316L, ceramic, Viton®
Protection class	connection box IP65, probe IP43
Weight	approx. 15 kg, depending on options
Weather protection housing	SS304, thermal insulated, colour stainless steel natural
Approvals / Signs	CE

### Electrics

Power supply	230 VAC 50 Hz or 115 VAC 60 Hz
Power consumption	approx. 805 VA
Temperature controller / Sensor	electronic / PT100 (IEC-751)
Electrical connection	spring type terminals, clamping range 0,08 to 2,5 mm <sup>2</sup>
Switching capacity status contact (volt free)	230 VAC / 2 A, min. 5 VDC / 5 mA

Scope of delivery: sampling probe, mounting material, flange gasket, gasket for sampling pipe, operating manual

## FLOW CHART

This flow chart includes all possible variants

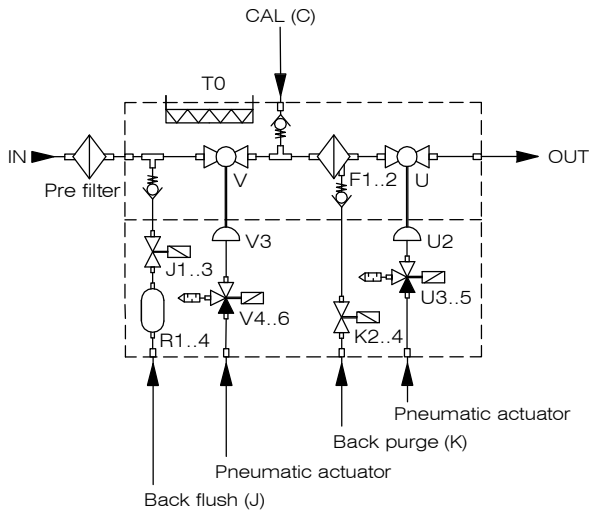

**Pressure characteristics in dependence of the gas flow  
(for new filter element and 20 °C)**

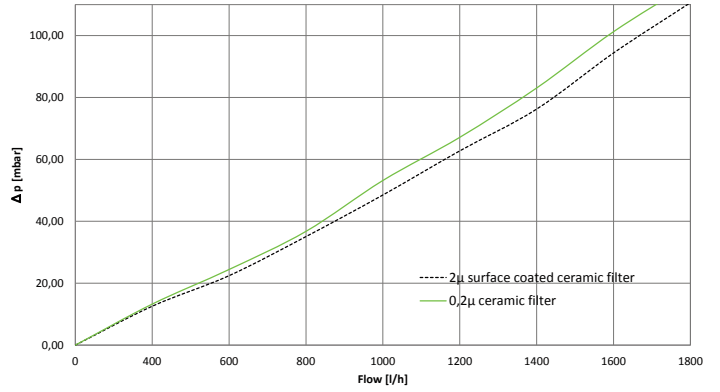

## DIMENSIONS

Dimensions in mm

